

Polaris® Ranger RZR Adaptive Side-by-Side Vehicle Project

by

Design Ability Inc.



Polaris® Ranger RZR Adaptive Side-by-Side Vehicle



The Mission

We want to provide opportunities for people with multiple disabilities to pursue a recreational motor sport.

There are hundreds of programs around the world as well as many organizations dedicated to the various forms of equine-assisted activities. Studies show that therapeutic riding participants experience increased confidence and improved self-concept, and that these activities aid social stimulation and lead to the acquisition of transferable skills.

While riding therapy is widely accepted, there is no such therapy for persons who want to operate a motor vehicle.

People with various cognitive and sensory disabilities could be helped with driving activities. Driving requires attention, reasoning skills and memory. Because driving builds knowledge as time progresses, simple tasks grow into complex skills.

Polaris® Ranger RZR Adaptive Side-by-Side Vehicle



The Story

I have two young sons. My older son and I ride dirt bikes and attend numerous motor sport events. As he gets older, these activities will become a greater part of our lives. My younger son has very severe Cerebral Palsy and many of these events are not accessible to him. He certainly can't ride a motorcycle. For years, I have tried to discover a way that I could introduce my younger son to our love of motor sports. I want these activities to be something that our entire family can enjoy together.

After test-driving the Side by Side Vehicle, I knew that this was what I had been looking for. I started to ask my son's therapists what they thought. I then started looking into the availability of equipment that would adapt this vehicle to meet the needs of many disabilities.

While researching the equipment that I would need, I found so many activities that have been made accessible to persons with many disabilities. There are quadriplegics who operate a sail boat with a sip & puff device. The Adaptive Sport Association has programs that offer adaptive kayaking, fishing, cycling and skiing, to name a few.

What I did not find was any group offering adaptive motor sports. I feel that my idea can help to fill that void. Many teens and young adults with disabilities will never be able to get a driver's license. That doesn't mean that they don't yearn for the opportunity to drive a vehicle. Providing this opportunity would be wonderful for many disabled persons and for their care-givers.

Polaris® Ranger RZR Adaptive Side-by-Side Vehicle



The Plan

The side by side vehicle can be adapted so that the person sitting in the passenger seat could operate the vehicle using a variety of control devices. For safety purposes, they would be accompanied by a supervisory person sitting in the driver's seat who would have the ability for complete vehicle over-ride.

For most users, a joystick would control steering, throttle and brake. Control could be limited based on the abilities of the user. The device could be changed out for other types of controls as needed.

From the driver's seat the accompanying adult would have the ability to override the steering, brakes and throttle. There would be an emergency shut-off to cover all eventualities.

The mechanisms needed for all of these controls are already available in the retail market, but would need to be customized as needed for this vehicle and the controllers.

The size of this vehicle would allow for it to be easily transported wherever it is needed. The user could operate the side by side in an empty parking lot or in field or trail. For the first time, these users would be able to drive through a mud-puddle or across an open field, and feel the same wind in their face that only a motor vehicle can provide.

Polaris® Ranger RZR

Adaptive Modifications by *Design Ability Inc.*



Buildup Flow Chart

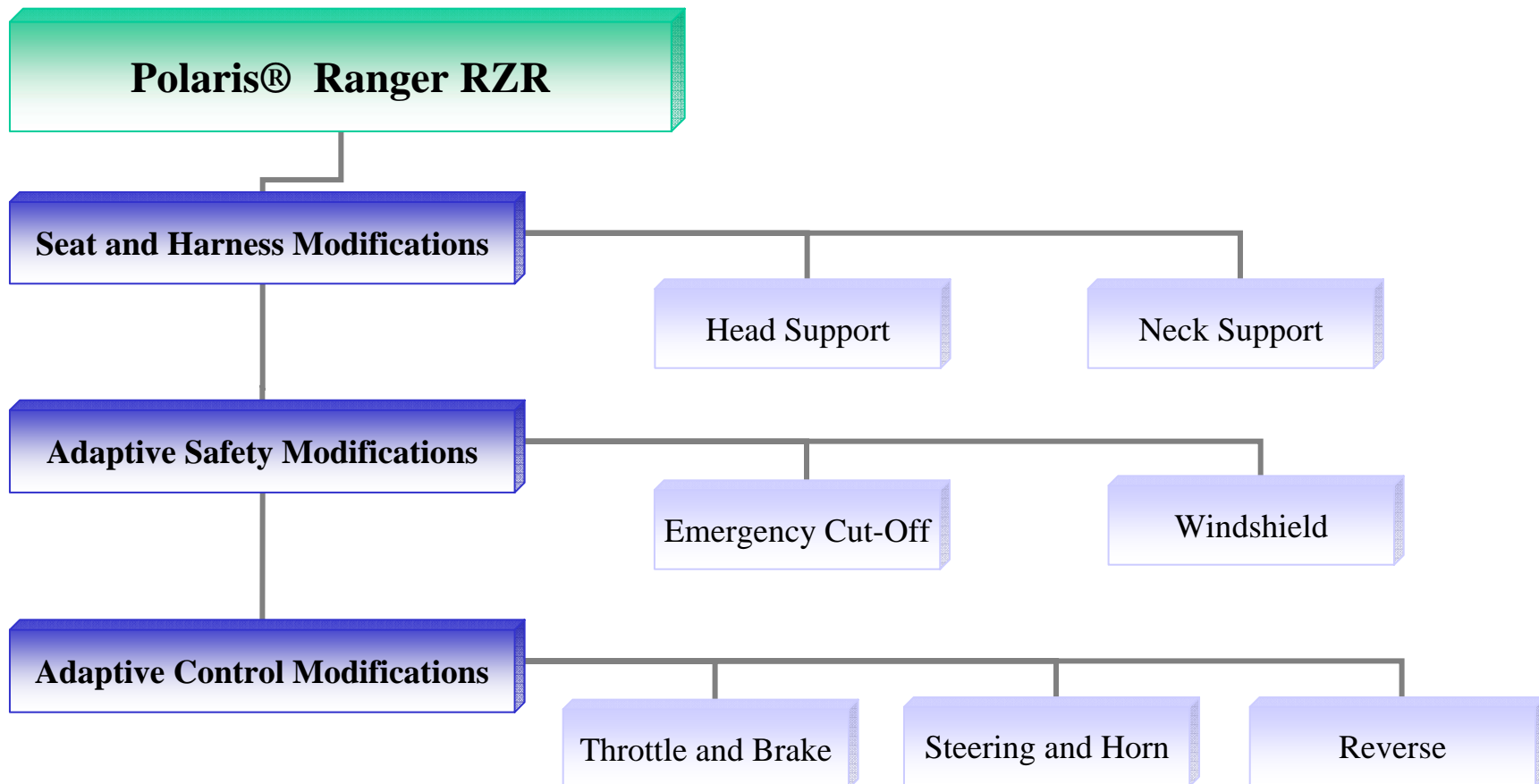

Adaptive Modifications by *Design Ability Inc.*

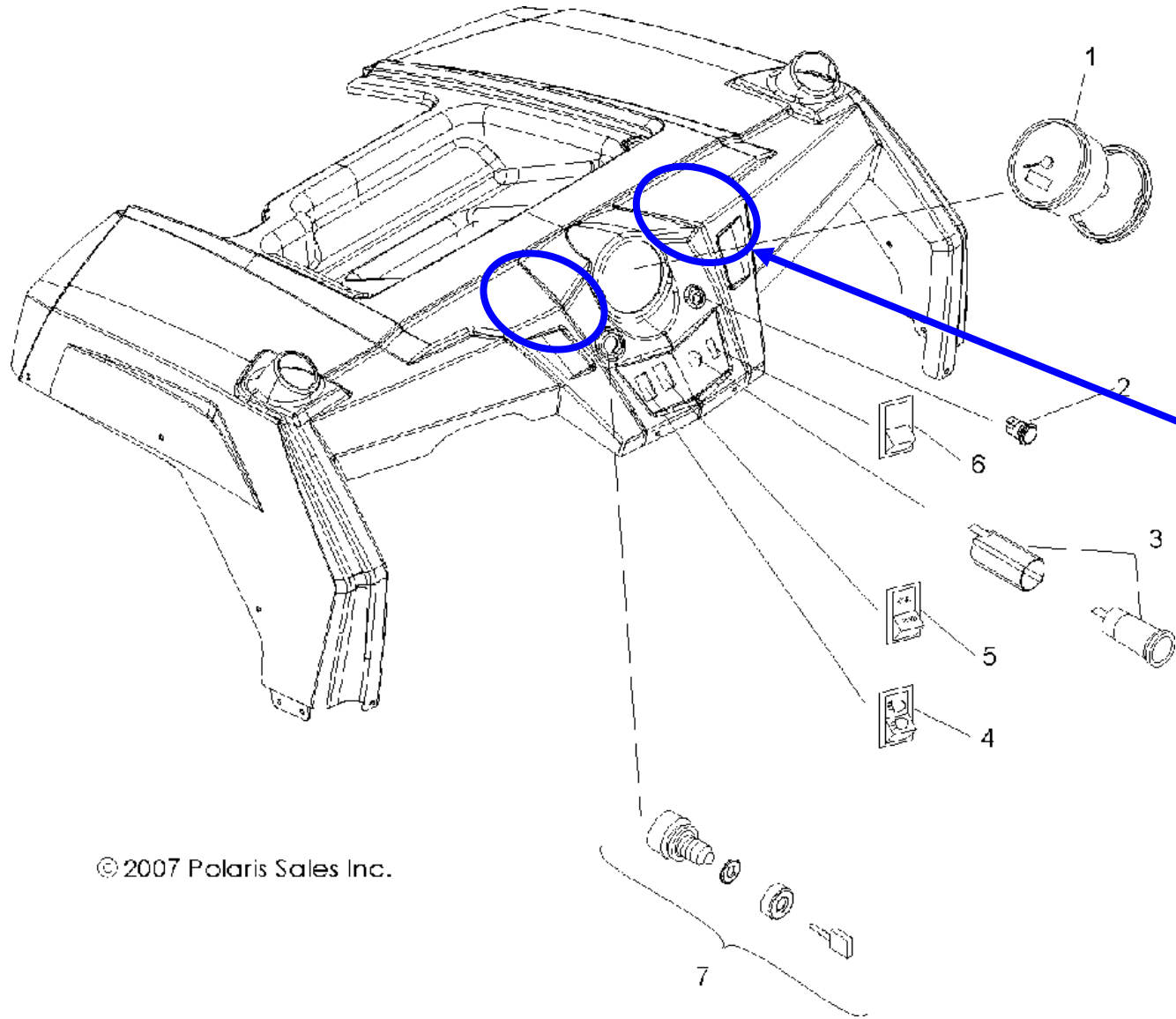

Need to add safety shut-off with locking brake function

© 2007 Polaris Sales Inc.

Adaptive Modifications by *Design Ability Inc.*

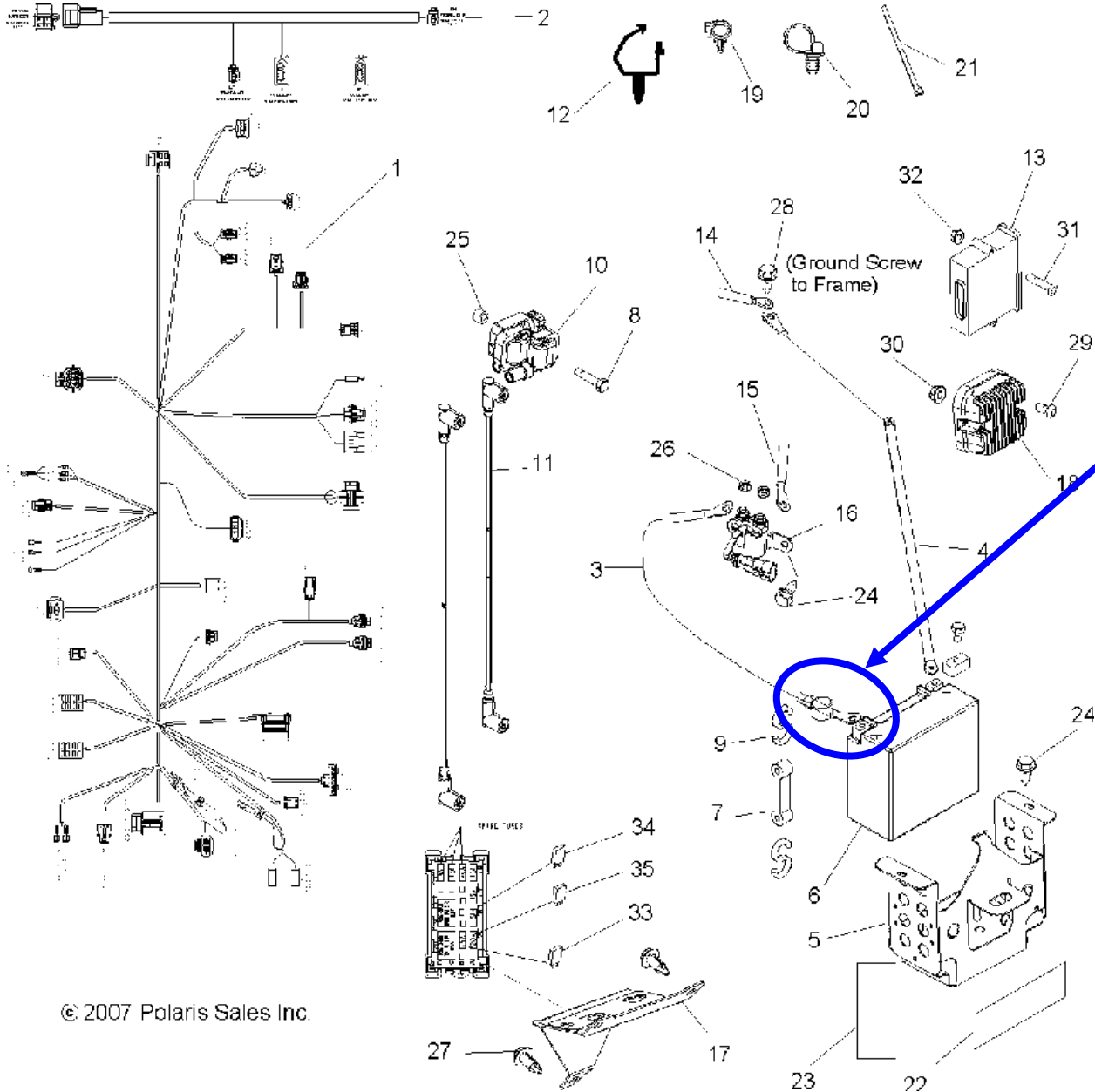

Need to add safety shut-off with locking brake function

© 2007 Polaris Sales Inc.

Adaptive Modifications by *Design Ability Inc.*

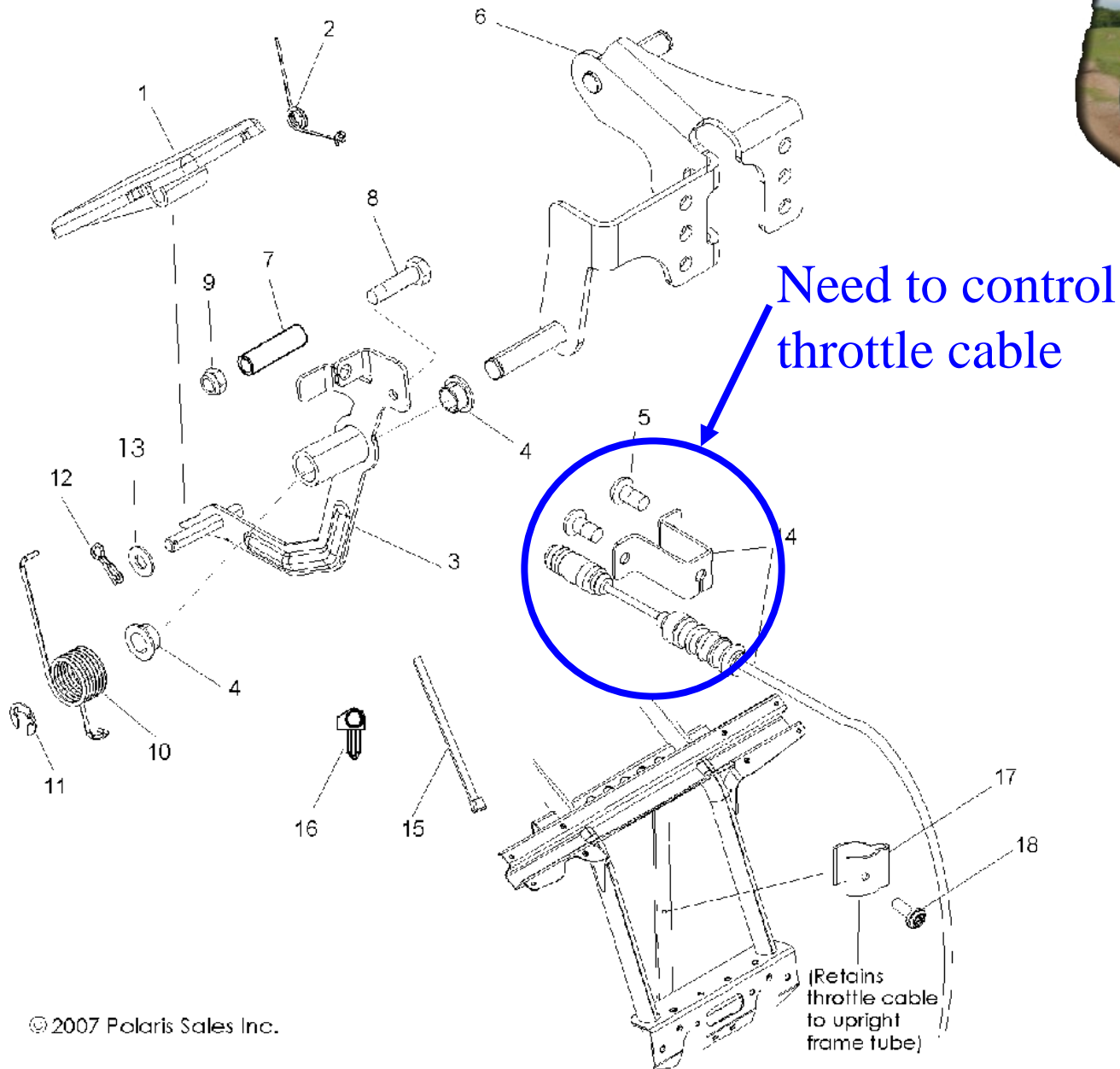

© 2007 Polaris Sales Inc.

Adaptive Modifications by *Design Ability Inc.*

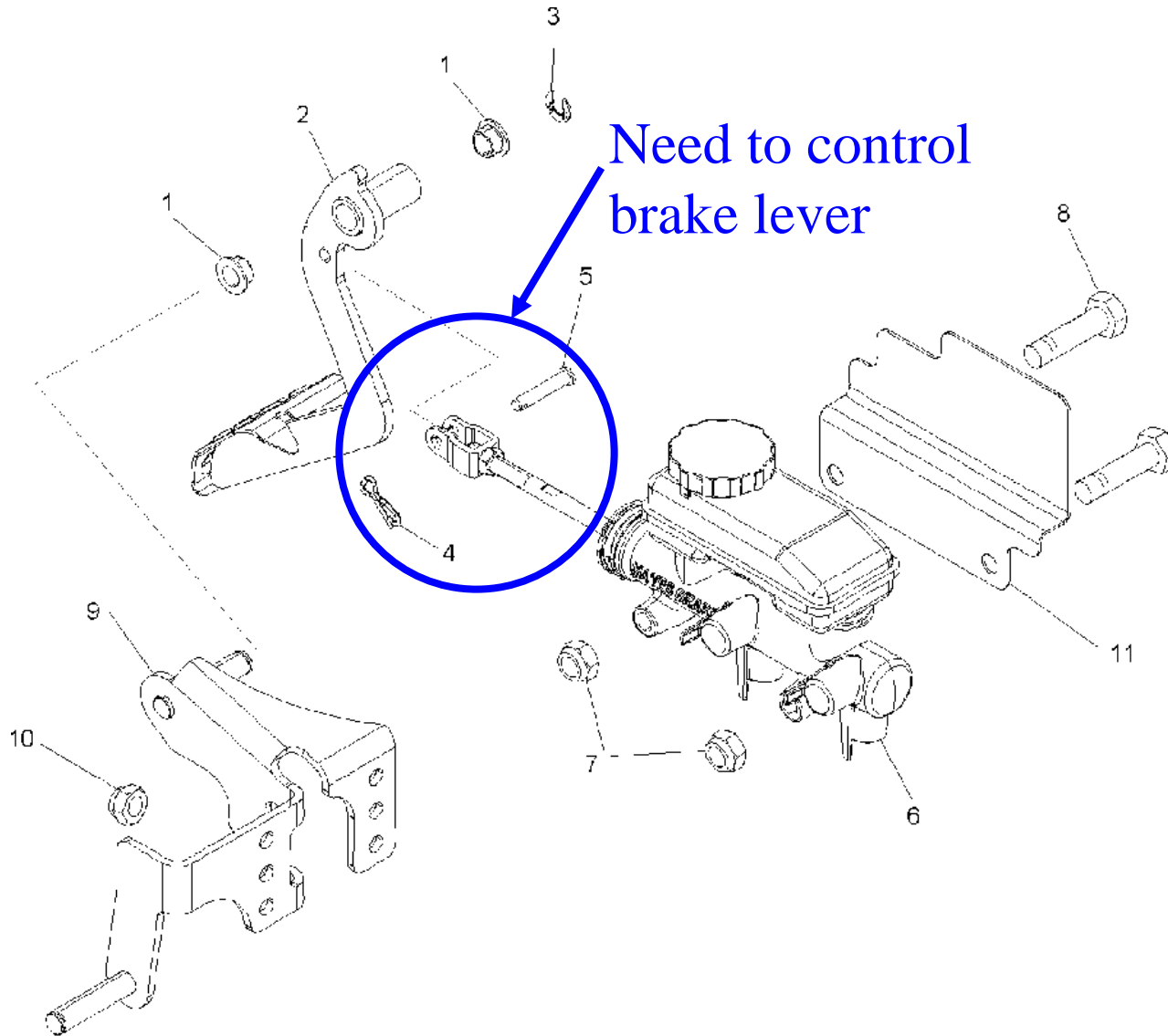

© 2007 Polaris Sales Inc.

Adaptive Modifications by *Design Ability Inc.*

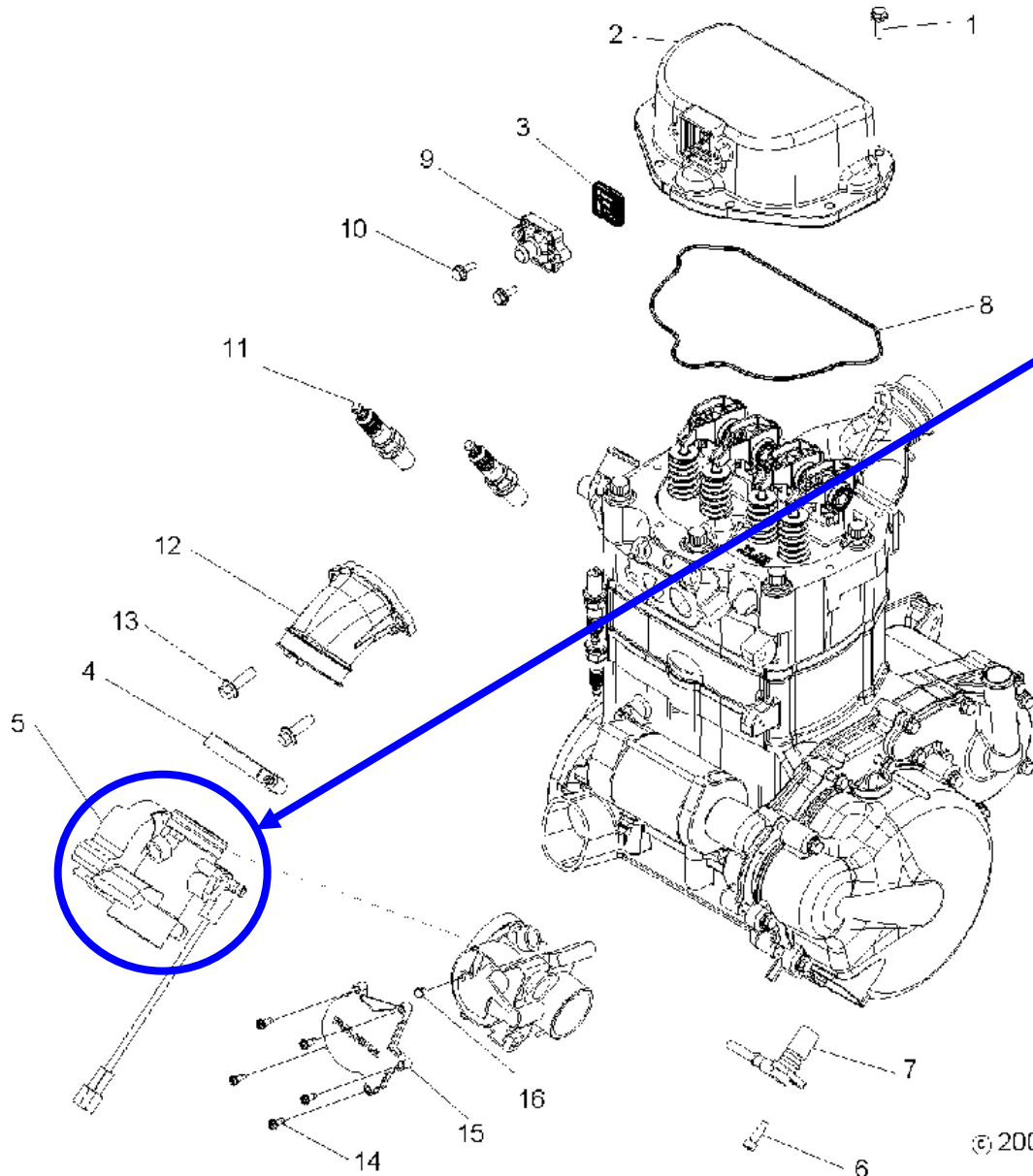

Need to control
throttle max
rev condition

© 2007 Polaris Sales Inc.

Adaptive Modifications by *Design Ability Inc.*

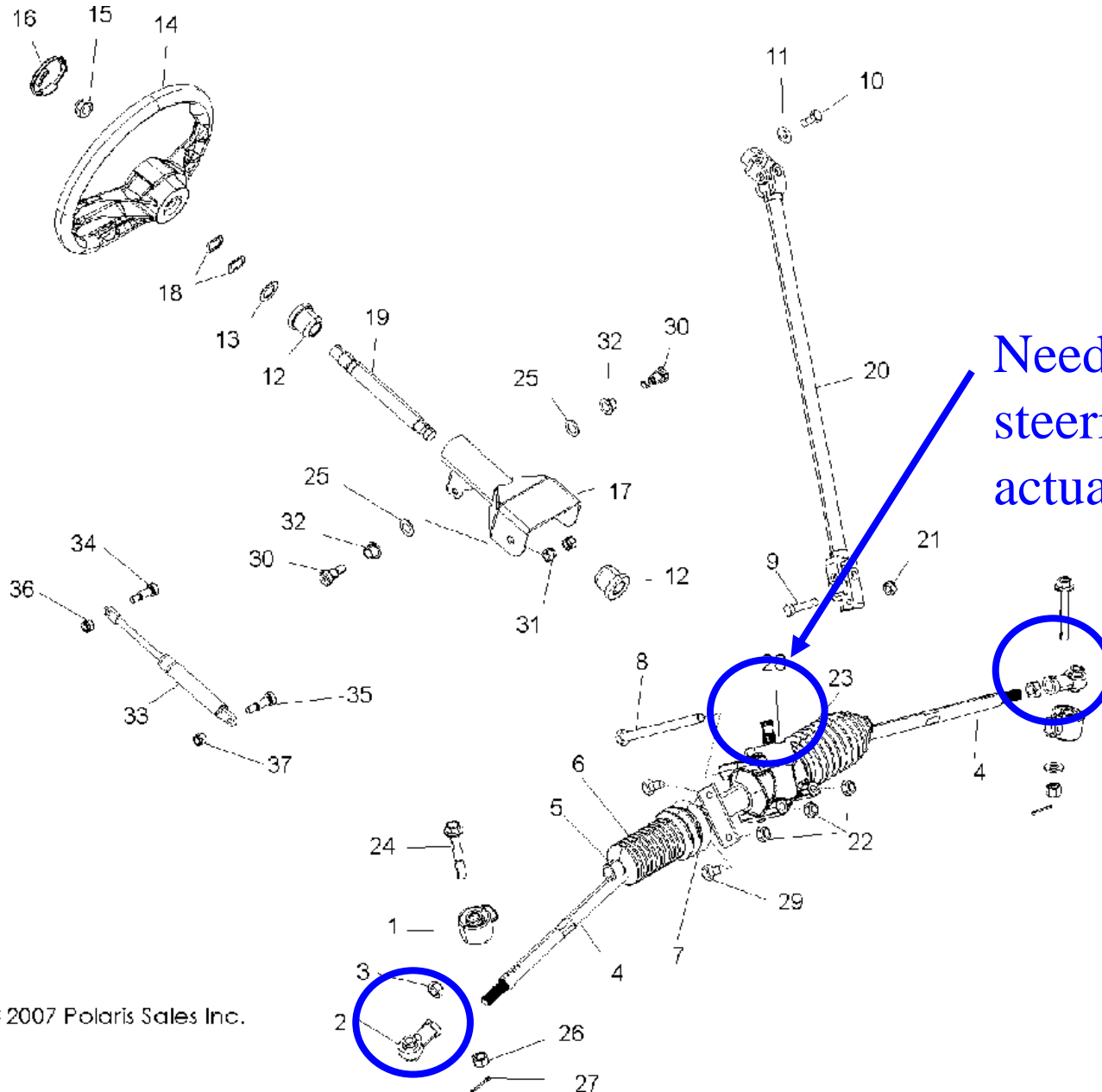

© 2007 Polaris Sales Inc.

Adaptive Modifications by *Design Ability Inc.*

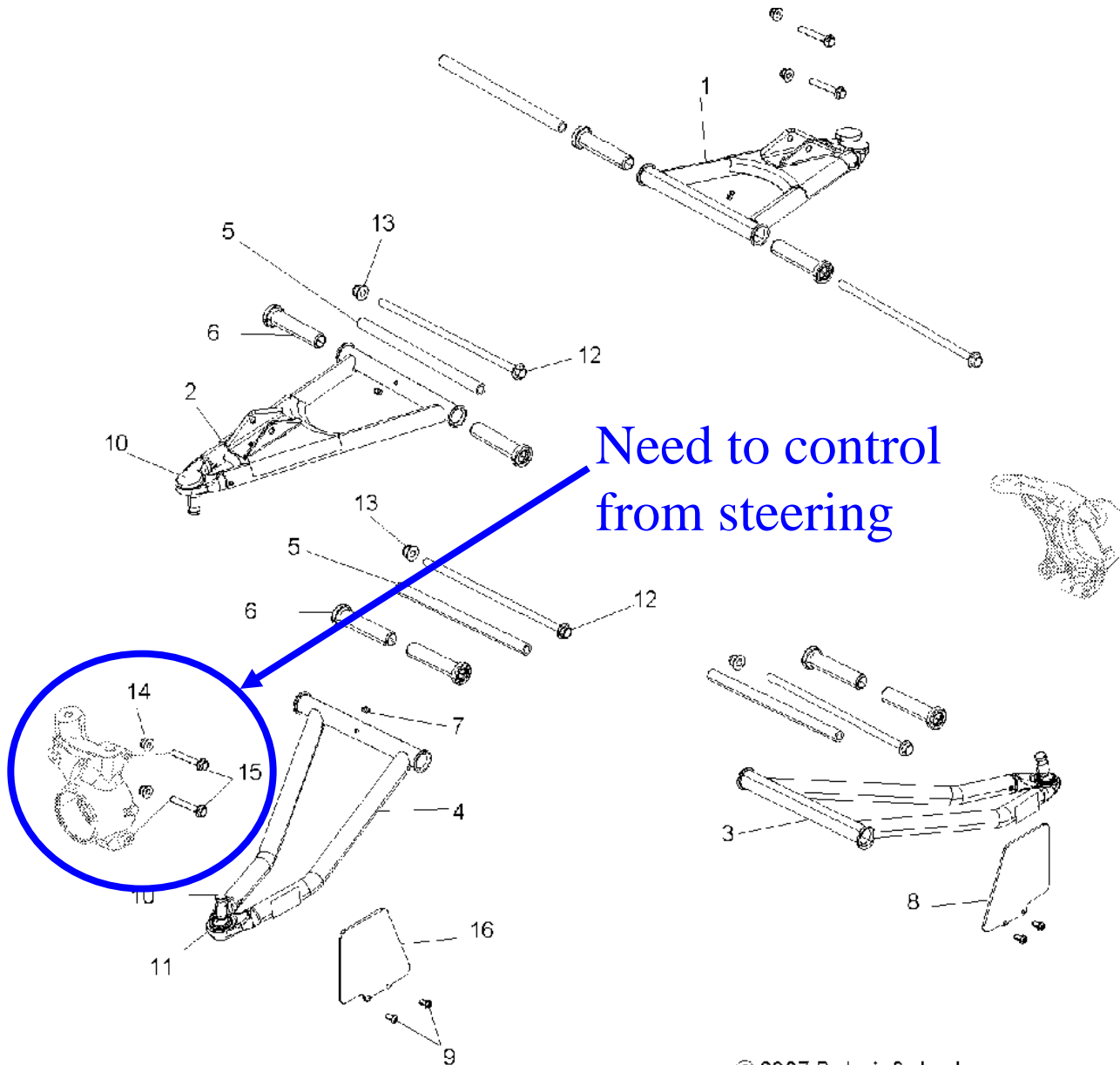

© 2007 Polaris Sales Inc.